

# Mendip Caving Group

## NEWS

NUMBER 242

DECEMBER 1994

### RESEAU DE LA DENT DE CROLLES AND CHARTREUSE MASSIF, SUMMER 1995

At the half-yearly general meeting, some of our more enthusiastic members suggested an expedition to Albania in the summer of 1995. Bearing in mind the political situation around Albania, and the consequent transport difficulties, we felt that Albania was an over-ambitious destination for 1995 (although with thorough planning it could be on for 1996). Other suggestions were Ireland, Italy, the Vercors, Picos de Europa, Yorkshire(!), Sima GESM and Algeria. These were all rejected, for whatever reason. This left us without an expedition for 1995.

So, we went back to the drawing board. After the Alps '94, we felt that for 1995 we wanted to visit an existing system, or well-known area, which would allow for all tastes (from easy walk-in caves to SRT) so that as many members as possible would wish to participate. It would also have to be within a day's drive of the channel ports. A group of us sat down with the Underground Atlas and eventually settled upon the Chartreuse Massif, in south-east France.

#### RESEAU DE LA DENT DE CROLLES

This popular system is situated within the spectacular karst massif of the Dent de Crolles, in the Chartreuse, just west of the main French Alps. It comprises several inclined levels of often complex passageways connected by many shafts. The cave may be entered at any of five places, the plateau shafts of the Gouffre Thérèse and the P40, the marginal cliff entrances of the Trou de Glaz and the Grotte Annette, and through the large open resurgence of the Guiers Mort. Its popularity stems from its ease of access, its considerable through-trip options, its fine passageways and shafts, its complexity and its generally challenging nature.

The major explorations took place between 1936 and 1947 by the team led by Chevalier and Petzl. These involved the most spectacular caving of their time, notable for the fact that much of the exploration was carried out upwards from the Glaz to the P40. Since then there have been regular extensions; notable were the connection from the Thérèse entrance, taking the depth to 623m, and the discovery of the great tunnels of the Métro level. The total length is now 53.8km.

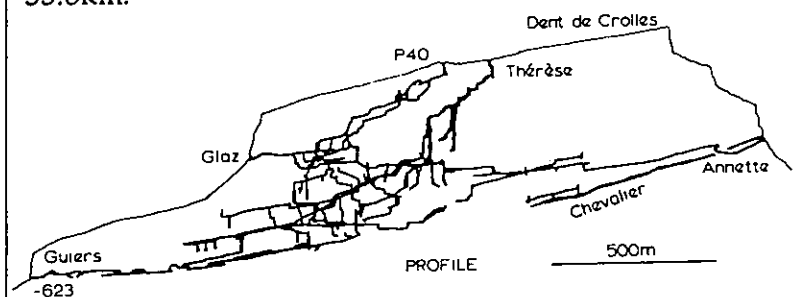

(from The Underground Atlas)

To the west of Grenoble, this area contains more than 600 caves amongst extensive lapies. There are two major systems, the Réseau de la Dent de Crolles (see box opposite) and the Réseau de l'Alpe with twelve entrances and 51km of passage. There are also many vertical caves including Puits Francis (-723m), Puits 508 (-481m), Réseau Ded (-780m) and Scilet de Genieux (-675m).

The dates for the trip are from 18th August to 3rd September 1995. All are welcome, whatever their ability. If you think you might be interested in taking part, please let us know (you can tick the appropriate answer on this year's subs request enclosed with this newsletter). There will be an update in the next newsletter but if you require more information before then, contact Martin Rowe or any other committee member.

## NORDRACH COTTAGE BOOKINGS

NIGHTS	GROUP	SIZE	NIGHTS	GROUP	SIZE
30 Dec-01 Jan	MEMBERS' NEW YEAR PARTY		10 Mar-11 Mar	SURREY SCOUTS	(16)
06 Jan-07 Jan	MEMBERS' WEEKEND		16 Mar-18 Mar	CHATHAM SCHOOL	(??)
27 Jan-28 Jan	WESTMINSTER SCHOOL	(12)	31 Mar-01 Apr	MEMBERS' WEEKEND	AGM
03 Feb-04 Feb	MEMBERS' WEEKEND		05 May-06 May	MEMBERS' WEEKEND	
24 Feb-25 Feb	KINGSTON UNIVERSITY	(16)	19 May-20 May	KINGSTON UNIVERSITY	(16)
03 Mar-04 Mar	MEMBERS' WEEKEND		02 Jun-03 Jun	MEMBERS' WEEKEND	

### 1995 MEETS PROGRAMME

DATE	AREA	EVENT	CONTACT	TELEPHONE
04 Feb	Mendip	Rescue Practice	John Crowsley	01179-652585
04 Mar	Mendip	Archaeology Walk	Yvonne Rowe	01252-872006
05 Mar	Mendip	Longwood Clean-up	Martin Rowe	01252-872006
01 Apr	Mendip	Annual General Meeting	Joan Goddard	01608-810382
01 Apr	Mendip	Annual Dinner	Arthur Spain	01749-679358
27 May-29 May	Yorkshire	Baping Gill Winch Meet	Geoff Beale	01734-722510
18 Aug-03 Sep	France	Chartreuse	Martin Rowe	01252-872006

### MCG - CAVE LEADERS

<u>DAN-YR-OGOF</u>		<u>OGOF FFYNNON DDU I</u>
Geoff Beale	01734-722510	Geoff Barton
John Beauchamp	01761-463143	Geoff Beale
Ian McKechnie	01932-228292	John Miriam
John Miriam	0181-393-3955	<u>ST. CUTHBERT'S</u>
Roger Wallington	01753-433841	John Beauchamp
<u>CHARTERHOUSE CAVE</u>		Malcolm Cotter
Charlie Allison	0181-393-5910	<u>RESERVOIR HOLE</u>
Nick Gilson	01934-417697	Geoff Beale

Accommodation in Yorks & Sth. Wales can be booked through the relevant cottage warden:  
 Yorkshire Northern Pennine Club Pat O'Connell 01729-822014  
 South Wales South Wales Caving Club Gary Vaughan 01202-679602

WEEKLY MEETINGS:	At the Group's Mendip headquarters on Wednesdays at 7.00pm. & at the Eclipse Inn, Egham, Surrey, on Thursdays from 9.00pm.
CAVING ACCOMMODATION:	For up to 30 people, is available at the MCG headquarters:- Nordrach Cottage, Charterhouse, Blagdon, Bristol, BS18 6XW
COTTAGE INFORMATION:	Tel: 01761-462797 Grid Ref ST51475606 OS 1:50,000 sheet 182
COTTAGE BOOKINGS:	Through the cottage warden please (address and tel. no. below)
COTTAGE FEES per night:	MCG members, member's children, SWCC and NPC £ 1.50 Guest clubs and member's guests £ 2.50
PREPAYMENT VOUCHERS:	(available to members only) 12 nights accommodation £15.00 25 nights accommodation £30.00
ANNUAL SUBSCRIPTION:	Full & Probationary Members: £25.00; Associate Members: £15.00 The subscription includes free day-time access to the cottage by the member, their children, and their accompanied guests



<b>SECRETARY</b> JOAN GODDARD	tel: 01608-810382
10 ENSTONE ROAD, CHARLBURY, OXFORD, OX7 3QR	
<b>TREASURER</b> MARTIN ROWE	tel: 01252-872006
10 GREENLEAS CLOSE, YATELEY, CAMBERLEY, SURREY, GU17 7SL	
<b>MEET SECRETARY</b> GEOFF BEALE	tel: 01734-722510
30 CHURCHILL CRESCENT, SONNING COMMON, NEAR READING, RG4 9RX	
<b>COTTAGE WARDEN</b> LEE HAWKSWELL	tel: 01923-819103
4a HAZELTREE ROAD, NORTH WATFORD, HERTFORDSHIRE	
<b>TACKLEMASTER</b> TIM FRANCIS	tel: 0181-876-1863
FLAT 5, 2 THE CRESCENT, BARNES, LONDON, SW13 ONW	
<b>EDITOR</b> YVONNE ROWE	tel: 01252-872006
10 GREENLEAS CLOSE, YATELEY, CAMBERLEY, SURREY, GU17 7SL	
<b>RECORDER</b> WAYNE HISCOX	tel: (WORK) 01749-672081x2213
3 KEWARD, GLASTONBURY ROAD, WELLS, SOMERSET, BA5 1TR	
<b>ORDINARY MEMBER</b> ARTHUR SPAIN	tel: 01749-679358
WAITANGI, LONG LANE, DINDER, SOMERSET, BA5 3PD	

\* CUSTODIAN TRUSTEES  
 \* JONATHAN ROBERTS  
 \* MALCOLM COTTER  
 \* PAT WALSH  
 \* PETER MATHEWS  
 \* REGISTERED CHARITY No 270088

\* NON-COMMITTEE POSTS  
 \* RESCUE WARDEN  
 \* CONSERVATION OFFICER  
 \* COTTAGE EXTENSION  
 \* MCG SHOP  
 \* AUDITORS

NAME TELEPHONE  
 JOHN CROWSLEY 01179-652585  
 TIM FRANCIS 0181-876-1863  
 WAYNE HISCOX 01749-672081x2213  
 SEE ANY COMMITTEE MEMBER  
 BRYAN TERRY AND DAVE TOOKE



**ON THE MOVE** Bill Platt to:  
30 Campbell Road, Burton, Christchurch,  
Dorset, BH23 7JY Tel: 01202-483762  
Jeremy Gilson to: 2 Purdue Close,  
Worle, Weston - Super - Mare, BS22 0QQ  
Tel: 01934-515689  
Bill Headington to: 32 Combend,  
Radstock, Bath, BA3 3AN  
Steve Albino (after Xmas) to: 177  
Degraw, Brooklyn NY 11231, New York, USA  
Charlie Alison: new Tel: 0181-224-7591

**WELCOME** to Huw Jones, Reggie Pain, Rupert Knowles and Nicola Barrell, accepted as probationary members.

**1995 SUBS** It is that time of year again folks, so with this newsletter you will find the usual subs renewal form and CCC permit. If you are a student, a person on a low wage or are living abroad, then you can apply in writing to the secretary for reduced subs. Your letter and the committee's decision will be completely confidential. You can also indicate on your renewal form whether or not you may be interested in next year's MCG trip to Chartreuse. You will not be committing yourself - we just need an idea of numbers for planning transport and accommodation. For more details of Chartreuse see the article on page 1.

**MENDIP MINERALS** The Home Counties North Group of the Geological Society is holding a meeting on 19th January at which Dr R F Symes will give a talk on "Mineralisation of the Mendip Hills". Dr Symes is Assistant Keeper, Dept of Mineralogy, British Museum (Natural History). MCG members are welcome to attend, whether they are geologists or not. The meeting is at 8pm at the Watersmeet Centre (the Local Government headquarters) which is near the centre of Rickmansworth. The lecture will be preceded by the Geological Group's AGM but I am assured this shouldn't take long.

#### **YV\* SDROPPINGS**

TF: Ralph said he knows of caves in Bordeaux

YR: Doesn't he mean cellars in Bordeaux?

RC: If we don't go caving soon we'll be overdue before we've started!

JG: I'm competitive when it comes to shove ha'penny!"

**EARWIG** in on the committee meeting held 3.12.94... Key deposits: are being transferred to the COIF deposit account for more interest (4.28%) prior to an appropriate account being sought - maybe a building society high interest account (7-8%), Income Bonds or National Savings... Duracell batteries: are now in the cupboard in the members room (6 room) at the cottage. There are ten at present but we will be getting more from Bernard Reeves who can get them cheaper than retail prices - see any committee member... Fire extinguishers: at the cottage need testing. Committee will contact ex-member (and fireman) Brian Murlis for advice on the matter... A drying room: has been requested again after members and guests were caught leaving the 3kw heater in the changing room on all night to dry gear! As a result a member removed the fuse - next time the heater will be removed. A drying room has been discussed before - one option is to heat the shed but our electricity supply will not cope. Air vents in the shed walls were suggested. Can anyone offer any practical suggestions?... A spin drier: to extract water from heavily drenched gear has been installed in the cupboard under the battery charging area - between the changing room and tackle store. There is a bowl to catch the run-off from the hose. (Ed: might help those softy cavers who can't put on damp gear to go caving) Gear can then be hung in the shed overnight to dry... Bosch drill: request for an Ortleib bag to wrap the drill in to seal and protect it when underground. Necessary when used on wet trips such as Daren Cilau... also a separate battery back-up pack for the Bosch. Committee to investigate price and check if it is compatible without pulling the drill apart... Committee to also look into the merits of Hilti drills as they are supposed to be heavy duty and better than a Bosch... **"MCG"**: Committee to look into how we may protect our "trademarks" such as "MCG" (on sweatshirts etc.) It has been noticed that there are companies who call themselves MCG, as in "MCG Closures", so do we need to register our use of the initials "MCG"?

**PHONE DAY** On 16th April 1995, all BT local codes will be replaced with new national codes. "1" will be included after the initial "0", for example 0749-62797 becomes 01749-62797. Exceptions include Bristol, 0272 which becomes 0117 and an extra digit "9" is added to the customer number. For example, 0272-62585 becomes 0117-962585.

The code to dial abroad from UK also changes from "010" to "00", for example 010 33 61858232 becomes 00 33 61858232. Please check your number on the address list (back page) and advise Martin Rowe if any mistake has been made.

## COTTAGE DOINGS

**ABSENT TACKLE** The committee is quite concerned about tackle that is either not being returned or going missing from the tackle store - in particular the nine(!) pulleys. It is worrying because tackle can ONLY be taken and signed out by full members - they are the only ones with a key for both the tackle store door and the Cotag access system. The other worry is that maybe the tackle store door and/or Cotag system are not being locked after use. Whatever the reason, there is tackle going astray and it is not being signed out or returned. Replacing this missing tackle is costing the Group dear and although the committee is unanimous in not wanting to play Big Brother, it might eventually have to resort to a "spy" option. The Cotag system automatically records the identity of each key fob each time it is used. We are therefore able to tell which members enter the cottage, the day and the time BUT WE HAVE SO FAR NOT USED THIS FACILITY. Should tackle continue to go astray, we could bring this facility into use. Please don't force us to resort to these measures - it really goes against the grain and is not what the system was intended for, so play fair, sign out the tackle you use and please return it. What on earth does anyone need nine pulleys for anyway??

**MOAN, MOAN, MOAN** Another moan I'm afraid. When members arrived at the cottage recently they found a note asking for the bolts on the side door to be left unlocked. This would have rendered the Cotag security system pointless. Just to remind you: the reason we spent huge sums on the Cotag system in the first place was to make it impossible for ex-members who refused to return their Yale keys to use and abuse the cottage facilities (as they often did). The committee had to come up with a way of keeping out anyone who no longer had a right to be there and the Cotag security system satisfied the requirements. Once inside the cottage ex-members had access to the tackle store, the library, showers, cooking facilities, bunks, etc. all of which we members pay for through our subs and cottage fees. If we leave the bolts unlocked on the side door we are simply reverting to the pre-Cotag system of cottage entry, and news would soon get around I'm sure. If you can't or won't pay £10 deposit for a Cotag fob then you will have to take pot luck on someone being at the cottage, or just wait for a keyholder to arrive! As a result of this abuse of the system, the lock on the side door is to be blanked off after Xmas so it can't be used from the outside anyway.

**A REMINDER** to please put all black bags of rubbish into blue Cleanaway bags. Cram as many black bags into each blue bag as possible, to save money as these blue bags are quite expensive. If necessary trample on the black bags first to reduce the bulk a bit. Cleanaway will not remove any rubbish that is not in their blue bags. Put all burnable rubbish in the marked bin in the kitchen then burn it before you leave the cottage. Also, beware of imposters leaving their rubbish in our pick-up point outside the cottage - some were caught at it once...! Thanks for your co-operation.

**STOP THIEF!** Thinking of going to GB? Worried that your car may be broken into? Thinking of leaving your car at the cottage? Then think again! It appears that nowhere is safe now - on two occasions recently, members have had petrol stolen from their car WHEN PARKED OUTSIDE THE COTTAGE. Each time, their car was parked in front of the gate to the field next to the cottage (rather than inside our boundary wall). Fuel lines were cut and the filler caps were wrenched off to increase petrol flow. The filler caps were taken away - if these were lockable, and the cars involved have central locking, the thief can make a copy of the car's ignition key! It's difficult to know what advice to give to members - it seems that your car will be vandalised if you park at GB and will be vandalised if you park at the cottage! To make matters worse, this vandalism occurred whilst members were present inside the cottage but unaware of the events happening outside. Coincidentally, the thefts of petrol both occurred on days when motor bike events were taking place at the stadium at Tynning's Gate and motorbikes were seen setting off from outside the cottage on the day of the second theft. Be vigilant, and if possible park inside our boundary wall rather than on the roadside. Alternatively, label your fuel cap "diesel" as they seem to go for 4-star!

**MANY THANKS** This item should have gone in the Forum doings in the last newsletter. The committee, on behalf of the members would like to thank... Pat Walsh for mending the fire grate... Bryan Pittman, Don Vosper and Arthur Spain for testing the electrical system re shocks in the showers... and Roger Wallington and Mike Lovell for the new wall map in the lounge. Thanks also to all the other members who have done odd jobs and repairs around the cottage.

**IN MEDICAL EMERGENCY** the nearest hospitals to the cottage are Weston-super-mare (closest but via country lanes) and Bristol (quickest, if no other traffic, eg on Sunday).

## LEAD AND YOU - A WARNING

This article is based on extracts from a Health and Safety Executive pamphlet for lead workers. In the case of MCG it applies to caving, and in particular to digging in caves that are contaminated with "heavy metals" such as Cadmium, Lead, Zinc, etc. These substances are harmful if not treated with respect. This applies mainly to the extraction of these metals such as mining, but applies equally to activities in areas of known contamination, such as Upper Flood, Velvet Bottom and Singing River Mine.

### *The main routes of exposure are:*

- \* Breathing in dust, vapour or fumes.
- \* Ingesting (eating or drinking) material on food, in drinks or on smoking materials.
- \* Contamination through the skin, particularly in wounds.

### *The measures you can take:*

- \* Try to keep dust to a minimum, keep the work area damped down. Keep your face as far away from the dust source as possible.
- \* Share the task between as many people as possible to minimise the exposure of each person.
- \* Think about the state you are leaving the site in and what might happen to others as a result.
- \* Wastes taken off site will be contaminated/hazardous for the purposes of the law, they must be bagged and labelled as such.
- \* There is an obligation to prevent the spread of contamination. This includes the export of materials airborne, in watercourses, on vehicle wheels, inside vehicles, on clothing, etc.
- \* Think before you eat, drink or smoke. Leave the contaminated area and wash hands and face before doing any of these.
- \* Think about your health. If you start to suffer headaches, nausea, upset digestion or other ill effects (Ed. and you haven't simply got a hangover!), seek medical advice.
- \* Always bag up dirty clothing and equipment until it can be properly cleaned.
- \* Always thoroughly clean down afterwards any third party wash area (eg shower) that you use for decontamination.
- \* Wash and change before you go home.
- \* Never clean your equipment or clothing in areas you clean yourself in.
- \* If a woman is pregnant the lead in her blood can pass into the blood of the baby she is expecting and may affect its development. It is important to keep the amount of lead in the blood of women of reproductive capacity as low as possible.

## THE GEMLOCK DESCENDER

by Timothy Francis

The prototype of the Gemlock had been field tested on the SWCC expedition to the Berger in 1993, and reports had been promising. The final version, in delightful purple, finally made its public debut at the BCRA Conference this year. Being a committed rack user myself I was intrigued to see a plummet - proof Stop in action. It seemed ok on the climbing wall so a quick trip in Yorkshire was called for.

Due to adverse weather conditions Jingling Pot was selected as the testing ground for the Gemlock. Several people were being introduced to the delights of SRT from the bouncy trees so I opted for the bolt route on the side of the pot. This has several in situ Petzl hangers although an 8mm hanger is also required to convert the rig into a 'Y' hang. This was a useful introduction into the locking mechanism of the Gemlock. Your body's weight acts upon the rope and pulls the handle down into a locked position. No extra lock is required although I preferred to hard lock the handle with a loop of rope for extra security. From a rigging perspective the length of loop required on a reelay was almost identical to that required for a rack, and less than that needed for a Stop.

Once past the reelay I found rethreading the Gemlock a relatively easy process. The rope weaves around the friction pillars in a manner similar to that of a Rack, and simpler than a Stop. An *aide memoire* is etched onto the side but I still checked and double checked the threading just in case! The moving top plate of the Gemlock is held in place by a safety catch button which clicks into place once the side is closed. The metal button has to be depressed before the Gemlock can be opened or closed. This procedure would seem to be the weakest point of the design and I will be interested to see how it stands up to the muddy conditions of Mendip.

It took me a while to get used to lifting the handle to descend. Controlling the speed of descent was relatively easy, although I found my arm getting tired towards the end of the pitch. This resulted in several jerky bounces as I struggled to raise the handle. Undoubtedly practice makes perfect but I found that the angle of my arm required to raise the handle rather uncomfortable. The rope can be threaded to increase friction but for someone with a light build(!) I do not think this setting will ever be used.

In conclusion the Gemlock is a welcome newcomer into the SRT market. Any new innovations are bound to improve competition and hence benefit the caver. Its design attempts to cover the middle ground between Rack and Petzl Stop, and succeeds in being relatively easy to use. It is now available in most of the caving retail outlets or alternatively direct from the manufacturers : Gemini Rescue Equipment.

# LOADING, USING AND LOCKING OFF

## GemLok (PAT. APPLIED FOR.)

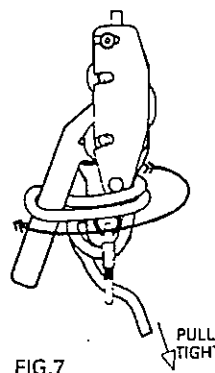
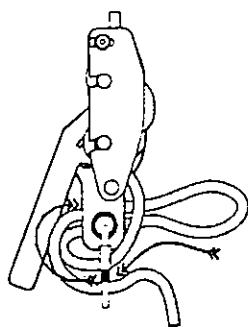
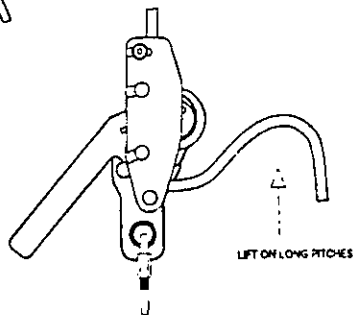
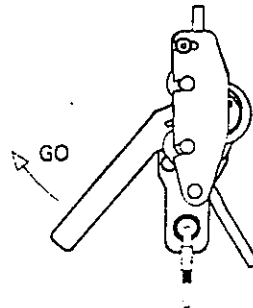
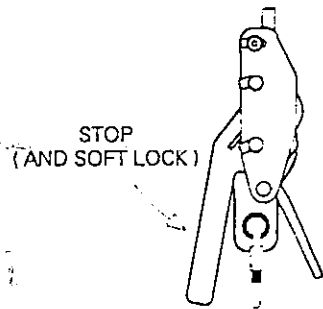
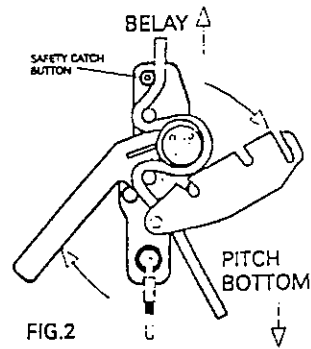
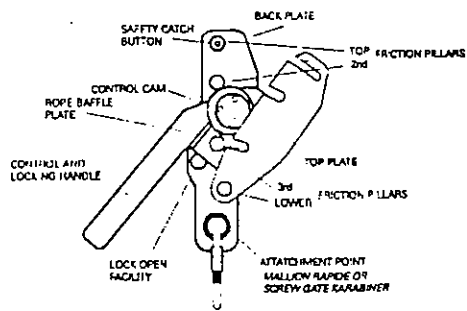

## THE SECRET OF THE CAVE

An extract from a book that Don Vosper sent to Joan who thought it would make an amusing Christmas competition.

They felt rather like Aladdin must have felt when his oil lamp revealed the wonders of the magic cave. But instead of glittering jewels, the light from the torches illuminated cream-coloured stalactites hanging from the roof of a vast cavern. It was like being in the gallery of a great theatre, hewn out of rock, but the walls were of fantastic shapes, bulging in places and ridged in others like the pipes of a huge organ. And a silvery coating to the rocks glistened and shimmered in the light.

They looked down for several minutes without speaking. The strangeness and wonder of it all seemed to take their breath away. "Look - over there!" Gerry whispered. He directed his torch to the far end of the cave. There was a queer, dark-coloured heap that was obviously not rock. "What is it?" asked Jane. "What do you think?"

Well, what do you think? Answers to the editor please who will buy a drink for the person who comes up with the wittiest or most interesting interpretation. I will publish the winner's name and his/her answer (if it does not contravene the Obscene Publications Act!).

While we are at it - any guesses as to the identity of the gentleman to the back of the picture. My guess is that it is Tony Knibbs! If so, perhaps he can tell us what it actually was.



The light from the torches illuminated cream-coloured stalactites hanging from the roof of a vast cavern

### SRT PRACTICE?

Fancy abseiling from a railway viaduct in South Wales? Go ahead. Jump! Merthyr Tydfil Borough Council, owner of the Pontsarn viaduct, is perfectly happy. The Welsh Office? No problem. Ted Rowlands, the local MP? He'll be right behind you. Metaphorically speaking. Be warned, though. The second you touch down, you'll have a National Parks officer on your back. Metaphorically speaking. A plan to run climbing and abseiling courses from the viaduct has won approval from everyone except Brecon Beacons National Park, owner of the land beneath the arches. It reckons such activities would be detrimental to the area. So for the time being, abseiling at Pontsarn can only be a let-down. Metaphorically speaking. (Guardian, 24-11-94)

Ed: Who owns the air space between the viaduct and the ground? If you abseiled to about a foot above the ground, would you be on National Park land? You couldn't "land" but it would make good practice for changeovers while still on the rope!

### AND FINALLY...

...it's an ill wind. Breaking wind is healthy and should not cause embarrassment, a Dutch group said yesterday. The Liver and Intestine Foundation say breaking wind 15 times a day helps to expel digestive gases which cause discomfort. It says it's launching a publicity campaign to try to clear the air.



"What did the doctor suggest for your wind problem, dear?"

(Guardian/Reuter 10-11-94)



MCG Members at 12-Dec-94 including new BT area codes

FNp STEVE ALBINO		177 DEBRAW, BROOKLYN, NY 11231, NEW YORK, USA
FKp JAMES ALLEN	0181-393-8250	53 EMELL BY-PASS, STONELEIGH, EPSOM, SURREY, KT17 2PY
FKp CHARLES ALLISON	0181-224-7591	69 CHEAM ROAD, EMELL, SURREY, KT17 3EG
ANp VICTORIA ARBIZU	0034-54276981	CALLE MONTE CARMEL 51-2/B, 41011 SEVILLA, SPAIN
AKp CAROL BALL	0117-9498171	47 WILLIAMS CLOSE, LONGWELL GREEN, BRISTOL, AVON, BS15 6BS
PNp NICOLA BARRALL	01222-766676	30 CHARTMELL DRIVE, LISVANE, CARDIFF, CF4 5EZ
FNp DOMINI BARRETT	01275-462449	12 CHELSFIELD, BACKWELL, BRISTOL, AVON, BS19 3LU
FKp GEOFF BARTON	01932-849241	THE LODGE, THE HEATH, WEYBRIDGE, SURREY, KT13 0UB
FKp DAVE BAXTER	01923-467072	123 PRINCES AVENUE, WATFORD, HERTFORDSHIRE, WD1 8LP
FKp GEOFF BEALE	01734-722510	30 CHURCHILL CRESCENT, SONNING COMMON, NR READING, RG4 9RX
FKp JOHN BEAUCHAMP	01761-463143	ST HUGHS COTTAGE, CHARTERHOUSE, BLAGDON, BRISTOL, BS18 6XR
FKp STEVE BEDFORD	0181-783-1265	5 MYRTLE ROAD, HAMPTON HILL, HAMPTON, MIDDLESEX
FNp ANDY BELLAMY	01705-670420	66 HARTLEY ROAD, PORTSMOUTH, HAMPSHIRE, PO2 9HX
FKp JEFF BLACKGROVE	01372-745977	2 WEST HILL, EPSOM, SURREY, KT19 0HR
FKp DAVE BRIGGS	01624-623429	51 WYBOURN GROVE, ONCHAN, ISLE OF MAN, IM3 4AU
FKp PETE BULLING	01903-235431	22 CANTERBURY ROAD, MORTHING, WEST SUSSEX, BN13 1AE
FKp JEAN PAUL BURCH	01737-767738	10 RANELAGH ROAD, REDHILL, SURREY, RH1 6BJ
FKp FRED BURTON	01952-810143	17 BAYLEY HILLS, EDGEMOND, NEWPORT, SHROPSHIRE, TF10 8JG
FKp RICHARD CAREY	0117-9862029	HAMLEAZE, OLD BRISTOL ROAD, KEYNSHAM, BRISTOL, BS13 2AA
FKp MIKE CARSON	01753-655143	41 THE POYNINGS, RICHINGS PARK, IVER, DUCKINGHAMSHIRE, SL0 9DS
FKp PETER CATTEMULL	01252-873421	12 HARVEST CLOSE, YATELEY, CAMBERLEY, SURREY, GU17
FNp ROBBIE CHARNOCK	0181-570-4116	30 BASSETT GARDENS, OSTERLEY, MIDDLESEX, TW7 4BY
PNp CHRIS CLIPSHAM		W.O. & S.R. MESS, H.M.S. SULTAN, MILITARY ROAD, BOSPORT, PO12 3BY
FKp STEVE CONQUEST	0181-366-3276	10 McADAM DRIVE, ENFIELD, MIDDLESEX, EN2 0PS
FKp BEN COOPER	01256-64199	12 CORONATION ROAD, BASINGSTOKE, HAMPSHIRE, RG21 2HA
FNp JOEL CORRIGAN	01344-873613	2 WINDLEHERE HOUSE, WESTWOOD ROAD, WINDLESHAM, SURREY, GU20 6ND
PNp LORNA COTTER	01784-252643	249 FELTHAM HILL ROAD, ASHFORD, MIDDLESEX, TW15 1LU
HKp MALCOLM COTTER	01784-252643	249 FELTHAM HILL ROAD, ASHFORD, MIDDLESEX, TW15 1LU
FNp NORMA COTTER	01784-252643	249 FELTHAM HILL ROAD, ASHFORD, MIDDLESEX, TW15 1LU
FNp SONYA COTTER	01784-252643	249 FELTHAM HILL ROAD, ASHFORD, MIDDLESEX, TW15 1LU
FKp JOHN CROWSLEY	0117-9652585	11 ROSE WALK, FISHPONDS, BRISTOL, AVON, BS16 4JN
FKp LOUISE CURLEY	0181-979 2587	10 SONNING GARDENS, HAMPTON, MIDDLESEX, TW12 3PL
FKp BOB DAINE	01934-744389	16 ST ANDREWS ROAD, CHEDDAR, SOMERSET, BS27 3NE
ANp GEOFF DAVIES	01923-227154	72 ALDENHAM ROAD, BUSHEY, WATFORD, HERTFORDSHIRE, WD2 2ND
FKp MIKE DEAN	0181-399-9085	30 OAKHILL, SURBITON, SURREY, KT6 6DY
FKp RALPH DIMENT	01249-813785	57 THE PIPPIN, CALNE, WILTSHIRE, SN8 1JG
PKp JOYCE DINES	01460-30197	CHAFFEIGH FARM BUNGALOW, LAYMORE, WINSHAM, CHARD, SOMERSET, TA20 4NX
FNp ERIC DOWLEY		1 THE HILLWAY, PORTCHESTER, FAREHAM, HAMPSHIRE, PO16 8DN
FKp ADRIAN DUCKETT	0181-568-6211	68 ROXBOROUGH AVENUE, ISLEWORTH, MIDDLESEX, TW7 5WJ
FKp BILL DUCKLIN	0181-643-5105	1 ST ANNES COURT, STANLEY ROAD, SUTTON, SURREY, SM2 6RX
FKp STEVE EDDY	0117-9665222	33 SOMERSET TERRACE, WINDMILL HILL, BRISTOL, AVON, BS3 4LJ
PKp MIKE EELES	01784-431098	20 LARCHWOOD DRIVE, ENGLEFIELD GREEN, SURREY, TW20 0SH
AKp PHIL ELIOT	01736-787648	No 2 LITTLE KELYNACK COTTAGES, KELYNACK, NR. ST JUST, PENZANCE, CORNWALL, TR19 7RF
PKp LEE FERRIS	0181-889 4961	18 ANDRULA COURT, LORDSHIP LANE, LONDON, N22 5LJ
FKp GEOFF FISHER	01273-493755	OLD MILL HOUSE, SANDY LANE, NEPTON ROAD, HENFIELD, SUSSEX, BN5 9UX
FKp JULIAN FLAVELL		LISTA DE CORREDS 1A NORTE E 2A ORIENTE, EL SENTRO, GUTTIEREZ, CHIAPAS 29003, MEXICO
FKp JOE FRAMPTON	01734-404861	75A HIGHFIELD PARK, WARGRAVE, BERKS, RG10 8LB
FKp TIM FRANCIS	0181-876-1863	FLAT 5, 2 THE CRESCENT, BARNES, LONDON, SW13 0NN
FKp LINDA GATES	01276-24409	113 UPPER COLLEGE RIDE, CAMBERLEY, SURREY, GU15 4EY
FKp VANESSA GILL	0117-9652585	11 ROSE WALK, FISHPONDS, BRISTOL, AVON, BS12 4JN
PKp JEREMY GILSON	01934-515689	2 PURDIE CLOSE, WORLE, WESTON SUPER MARE, AVON, BS22 0GG
FKp NICHOLAS GILSON	01934-417697	24 COOMBE ROAD, WESTON SUPER MARE, AVON
FKp JOAN GODDARD	01608-810382	10 ENSTONE ROAD, CHARLBURY, OXFORD, OX7 3GR
FNp PETE GODDARD	01608-810382	10 ENSTONE ROAD, CHARLBURY, OXFORD, OX7 3GR
PKp DAVE GWILLIM	0181-740-4470	55 WELLINGTON COURT, MAYFIELD ROAD, LONDON, W12 9LT
PNp SHARON GWILLIM	0181-740-4470	55 WELLINGTON COURT, MAYFIELD ROAD, LONDON, W12 9LT
FKp PETER HARVEY	01597-810831	BRYNEMEL, CASTLE ROAD, RHAYADER, POWYS, LD6 5BA
FKp MIKE HASELDEN	01703-464491	3 THE CLOSE, THORNHILL PARK, SOUTHAMPTON, HAMPSHIRE, SO18 5RB
FKp DIGGER HASTILDW	01952-591118	15 CLOVER GROVE, RANDLAY, TELFORD, SHROPSHIRE, TF3 2AA
FKp LEE HAWKSWELL	01923-819103	4A HAZELTREE ROAD, NORTH WATFORD, HERTFORDSHIRE, WD2 5RD
PNp TIM HAYNES	01934-832234	8 THE EAGLES, YATTON, BRISTOL, BS19 4BR
FKp WILLIAM HEADINGTON		32 COOMBEND, RADSTOCK, BATH, BA3 3AN
FKp JULIE HESKETH	0181-876-1863	FLAT 5, 2 THE CRESCENT, BARNES, LONDON, SW13 0NN
PKp SIMON HEWLETT		4 POLHENNOR ROAD, FALMOUTH, CORNWALL, TR11 5UX
FKp WAYNE HISCOX	01749-672081x2213	3 KEMRO, GLASTONBURY ROAD, WELLS, SOMERSET, BA5 1TR
ANp PETE HOLLINGS		DEPT OF GEOLOGICAL SCIENCES, UNIVERSITY OF SASKATCHEWAN, SASKATOON, CANADA, S7N 0N0
AKp NEIL HUTCHINSON		7 GLADE ROAD, MARLOW, BUCKS, SL7 1DZ
ANp HELEN INGOLD	01442-242029	31 SPRING LANE, HEMEL HEMPSTEAD, HERTFORDSHIRE, HP1 3GJ
FKp PHIL INGOLD	01442-242029	31 SPRING LANE, HEMEL HEMPSTEAD, HERTFORDSHIRE, HP1 3GJ
PNp HUW JONES	01222-488615	11 MORLAIS STREET, ROATH PARK, CARDIFF, S GLANORGAN
FKp KATJA KAUFMANN	0181-450-9787	26A MELROSE AVE, WILLESDEN GREEN, LONDON, NW2 4JS

FKp	NICK KELLY	01275-858401	10 VALE END, NAILSEA, BRISTOL, AVON
FKp	ROY KEMPSTON	01252-835259	74 BUCKINGHAM WAY, FRIMLEY, CAMBERLEY, SURREY, GU16 5XP
FKp	DENISE KNIBBS	0033-61858232	LAS CLAUDIOS, THIL, 31530 LEVIGNAC, FRANCE
FKp	TONY KNIBBS	0033-61858232	LAS CLAUDIOS, THIL, 31530 LEVIGNAC, FRANCE
FKp	KEITH KNIGHT	01329-280386	7 HIGHHEAD, FAREHAM, HAMPSHIRE, PO15 6DL
ANp	SIMON KNIGHT	01749-675805	14 ROWDENS ROAD, WELLS, SOMERSET
PNp	RUPERT KNOWLES	01784-432833	4 BLAISE LANE, ENGLEFIELD GREEN, EGHAM, SURREY, TW20 0PH
FKp	PETE LINGWOOD	0181-805-2538	39 HOLMBRIDGE GARDENS, ENFIELD, MIDDLESEX, EN5 7EY
FKp	MIKE LOVELL	01734-663747	4 SETTRINGTON CLOSE, LODDON PARK, EARLEY, READING, BERKSHIRE, RG6 3XJ
FKp	JOHN MacMILLAN	01753-886029	4 HILL FARM ROAD, CHALFONT ST PETER, BUCKINGHAMSHIRE, SL9 0DE
FNP	BOB MARLES		YEM TREE FARM, KIRBY BELLARS, MELTON MONDRAY, LEICESTER, LE14 2ND
FKp	STEPHEN MARSHALL		BAD KINETON, TEMPLE HERDEWYKE, LEAMINGTON SPA, WARCS., CV33 0UL
PKp	JULIE MARSHALL-DEANE	01252-516444	28 AVON CLOSE, COVE, FARNBOROUGH, HANTS, GU14 9LN
FKp	PETE MATHEWS	01707-321018	15 BELLCOTT CLOSE, MELWYN GARDEN CITY, HERTFORDSHIRE, AL8 7BB
FKp	CLIVE MAYBURY	01275-851597	2 WOODFORD CLOSE, NAILSEA, BRISTOL, AVON, BS19 2UH
FKp	IAN McKECHNIE	01932-228292	21 CONYERS CLOSE, HERSHAM, WALTON-ON-THAMES, SURREY, KT12 4NG
FKp	ALAN MELLON	0181-751-0137	15 CHICHESTER WAY, FELTHAM, MIDDLESEX, TW14 0DF
PNp	DAN MILES	01734-724074	2 WELL COTTAGES, THE HAMLET, GALLONSTREE COMMON, SOUTH OXON, RG4 9DD
FKp	JOHN MIRIAM	0181-393-3955	44 CHESTERFIELD ROAD, WEST EWEY, SURREY, KT19 9GP
FKp	PETER MOSELEY	01458-860524	PENDLE COTTAGE, 82 MEAREWAY, WESTHAY, SOMERSET, BA6 9TZ
FNP	PAT NEWMAN	0171-537 9321	4 CUTTY SARK HOUSE, UNDISINE ROAD, LONDON, E14 9UM
FKp	GRAHAM OLD	01491-628596	1 UPPER HOUSE FARM COTTAGE, HARPSDEN, HENLEY-ON-THAMES, OXON, RG9 4JS
PKp	PETER O'ROURKE	0181-904-2174	1 BOLLERS COURT, MAYBANK AVENUE, WEMBLEY, MIDX, HA0 2SY
PNp	REGGIE PAIN	01892-545547	21 FERNHURST CRESCENT, SOUTHBOROUGH, TUNBRIDGE WELLS, KENT, TN4 0BT
FKp	BARRY PARKER	0181-572-3702	65 MOULTON AVENUE, HOUSLOW, MIDDLESEX, TW3 4LN
AKp	IAN PARRY	01296-715245	MELODY COTTAGE, 1 ORCHARD WAY, BOTOLPH CLAYDON, BUCKINGHAMSHIRE, MK18 2NG
ANp	ANN PITTMAN	01784-437540	36 MANOR WAY, EGHAM, SURREY, TW20 9NG
FKp	BRYAN PITTMAN	01784-437540	36 MANOR WAY, EGHAM, SURREY, TW20 9NG
FKp	MICHAEL PITTMAN		ROOM 6, 28 HENDREFOELAN, STUDENT VILLAGE, SWANSEA, GLANORGAN
FNP	BILL PLATT	01202-483762	30 CAMPBELL ROAD, BURTON, CHRISTCHURCH, DORSET, BH23 7JY
FKp	STEPHEN PORTER	01934-515686	79 BECKET ROAD, WORLE, WESTON SUPER MARE, AVON, BS23 1TE
FKp	JOHN PUDDUCK	01749-870383	1 MANOR FARM COTTAGES, THE GREEN, EASTON, SOMERSET, BA5 1ED
FKp	BERNARD REEVES	0181-864-3559	16A MEMBURY WAY, NORTHOLT, MIDDLESEX, UB5 4JD
FKp	JONATHAN ROBERTS	0171-735-9423	1 VNUXHALL WALK, LONDON, SE11 5JT
FKp	MARTIN ROWE	01252-872006	10 GREENLEAS CLOSE, YATELEY, CAMBERLEY, SURREY, GU17 7SL
FKp	YVONNE ROWE	01252-872006	10 GREENLEAS CLOSE, YATELEY, CAMBERLEY, SURREY, GU17 7SL
FNP	CHARLIE RUDDICK	01753-577676	9 AUGUST END, SLOUGH, BERKSHIRE
HNP	RON SAUNDERS	01494-813487	21 RUSHMOOR AVENUE, HAZLENERE, HIGH WYCOMBE, BUCKINGHAMSHIRE, HP15 7NT
FKp	DON SEARLE	01689-852116	14 HILDA VALE ROAD, FARNBOROUGH, ORPINGTON, KENT, BR6 7AH
FKp	BRIAN SNELL	01329-238341	38 SERPENTINE ROAD, FAREHAM, HAMPSHIRE, PO16 7EB
FKp	ARTHUR SPAIN	01749-679358	WATANGI, LONG LANE, DINDER, WELLS, SOMERSET, BA5 3PD
ANp	PEIER SPAIN	01494-715027	25 FORGE CLOSE, HOLNER GREEN, BUCKINGHAMSHIRE
FKp	GRAHAM SUTLIFFE	0181-643-4737	FAIRLAWN COTTAGE, FAIRLAWN ROAD, CROYDON LANE, BANSTEAD, SURREY, SM7 3AU
FKp	STEVE TAYLOR	01273-834035	58 CUCKFIELD ROAD, HURSTPIERPOINT, HASSOCKS, WEST SUSSEX, BN6 9SB
FKp	BRYAN TERRY	01533-432533	12 MEIR LANE, HOUGHTON-ON-THE-HILL, LEICESTERSHIRE, LE7 9GR
ANp	PAT TERRY	01533-432533	12 MEIR LANE, HOUGHTON-ON-THE-HILL, LEICESTERSHIRE, LE7 9GR
FKp	ADRIAN THOMAS	0117-9851095	17 CEDAR WAY, NAILSEA, BRISTOL, AVON, BS19 1QZ
PKp	RICHARD THORNTON	01258-459458	14 ALBERT STREET, BLANDFORD FORUM, DORSET, DT11 7HY
FKp	DAVID TOOKE	01923-238781	16 MUNDEN GROVE, WATFORD, HERTFORDSHIRE, WD2 5EE
FNP	DON VOSPER	01761-453214	5 FRANKLYN TERRACE, FARRINGTON GURNEY, AVON
FKp	ROGER WALLINGTON	01753-543384	125 LANLEY ROAD, SLOUGH, BERKSHIRE, SL3 7DZ
PKp	DAVID WALSH	0181-977-8414	58 MUNSTER ROAD, TEDDINGTON, MIDDLESEX, TW11 9LL
ANp	JUNE WALSH	0181-977-8414	58 MUNSTER ROAD, TEDDINGTON, MIDDLESEX, TW11 9LL
FKp	PAT WALSH	0181-977-8414	58 MUNSTER ROAD, TEDDINGTON, MIDDLESEX, TW11 9LL
PKp	BOB WANSTALL	01425-480642	31 ELUSTON GROVE, RINGWOOD, HAMPSHIRE, BH24 1FB
PNp	MARCUS WARD	01252-876783	15 JESSE CLOSE, YATELEY, CAMBERLEY, SURREY, GU17 7AH
PKp	MARK WARD	01373-813595	ESTORIL, HIGHBURY CROSSWAYS, COLEFORD, NR BATH, SOMERSET, BA3 5NJ
FKp	KEVIN WEST	01706-2228822	No1 OAKENHEAD WOOD, HASLINGTON OLD ROAD, RAWTENSTALL, ROSSENDALE, LANCS, BB4 8RR
FKp	ROBERT WHALLEY	01923-461596	55 PINNER ROAD, OXHEY, WATFORD, HERTFORDSHIRE, WD1 4EG
PKp	BARRIE WHITEHEAD	01458-273912	47 MOWRIES COURT, SOMERTON, SOMERSET, TA11 6NF
FKp	RICHARD WHITTINGTON	0117-9392751	27 LYVEDON WAY, LONG ASHTON, BRISTOL, AVON, BS18 9ND
FKp	CHRIS WHITTLE	01442-832994	17 APPLE COTTAGES, OLD DEAN, BOVINGDON, HERTFORDSHIRE, HP3 0EZ
FKp	ALLAN WICKS	01734-475628	39 SHERIDAN AVENUE, CAVERSHAM, READING, BERKSHIRE, RG4 7BB
PKp	FIONA WILLS	01252-838760	29 WINDSOR WAY, FRIMLEY, CAMBERLEY, SURREY, GU16 5YZ
FKp	NIC WOOD	01908-260841	60 DENMEAD, TWO MILE ASH, MILTON KEYNES, MK8 8JA
PKp	SUE WOOD	01908-260841	60 DENMEAD, TWO MILE ASH, MILTON KEYNES, MK8 8JA
PKp	GORDON WOODALL	01278-421802	37 ELIZABETH WAY, BRIDGWATER, SOMERSET, TA6 4NN
PNp	HELEN WOODFORD	01737-767738	10 RAMELASH ROAD, REDHILL, SURREY, RH1 6BJ
FKp	STEPHEN WYATT	01934-838953	17 STONEMELL DRIVE, CONDRESBURY, AVON, BS19 5DW
HNP	FRED YOUNG	01934-843274	WANSTEAD COTTAGE, SHIPHAM, WINSCOMBE, SOMERSET

141 members: 141 (p)aid, 0 (n)ot paid; 105 (K)ey holder, 36 (N)ot keyholder  
 (M)embership applied for, (P)robationary, (F)ull, (A)ssociate, (H)onorary

Committee underlined Trustees in italics

(c) MENDIP CAVING GROUP